

**SAMSUNG**

CL-29A5P / CL-29A5W  
CL-29A6P / CL-29A6W  
CL-29A7P / CL-29A7W  
CL-29M6P / CL-29M6W  
CL-34M9P

**COLOR TELEVISION**

**SAMSUNG**

**ELECTRONICS**

IMPORTER

Samsung Electronics Mexico S.A. de C.V.  
Saturno No. 44, Col Nueva Industrial Vallejo  
Gustavo A. Madero C.P. 07700, Mexico  
TEL) 52-5-747-5100

EXPORTER

Samsung Electronics co., Ltd.  
416, Mae tan-3dong, Pal dal-Gu,  
Suwon City, Kyungki-Do Korea

**Owner's  
Instructions**

# **Warning! Important Safety Instructions**

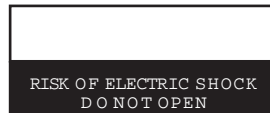

**CAUTION: TO REDUCE THE RISK OF ELECTRIC SHOCK, DO NOT REMOVE COVER (OR BACK). NO USER SERVICEABLE PARTS INSIDE. REFER SERVICING TO QUALIFIED SERVICE PERSONNEL.**

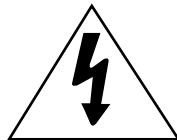

This symbol indicates high voltage is present inside. It is dangerous to make any kind of contact with any inside part of this product.



This symbol alerts you that important literature concerning operation and maintenance has been included with this product.

**Note to CATV system installer:** This reminder is provided to call CATV system installer's attention to Article 820-40 of the National Electrical Code (Section 54 of Canadian Electrical Code, Part I), that provides guidelines for proper grounding and, in particular, specifies that the cable ground shall be connected to the grounding system of the building as close to the point of cable entry as practical.

**Caution:** *FCC/CSA regulations state that any unauthorized changes or modifications to this equipment may void the user's authority to operate it.*

**Caution:** *To prevent electric shock, match the wide blade of plug to the wide slot, and fully insert the plug.*

**Attention:** *pour eviter les chocs electriques, introduire la lame le plus large de la fiche dans la borne correspondante de la prise et pousser jusqu'au fond.*

**Important:** One Federal Court has held that unauthorized recording of copyrighted TV programs is an infringement of U.S. copyright laws. Certain Canadian programs may also be copyrighted and any unauthorized recording in whole or in part may be in violation of these rights.

**To prevent damage which may result in fire or electric shock hazard, do not expose this appliance to rain or moisture.**

# Thank You for Choosing Samsung

Thank you for choosing Samsung! Your new Samsung TV represents the latest in television technology. We designed it with easy-to-use on-screen menus and closed captioning capabilities, making it one of the best products in its class. We are proud to offer you a product that will provide convenient, dependable service and enjoyment for years to come.

## Important Safety Information

 Always be careful when using your TV receiver. To reduce the risk of fire, electrical shock, and other injuries, keep these safety precautions in mind when installing, using, and maintaining your machine.

- Read all safety and operating instructions before operating your TV.
- Keep the safety and operating instructions for future reference.
- Heed all warnings on the TV receiver and in the operating instructions.
- Follow all operating and use instructions.
- Unplug the TV receiver from the wall outlet before cleaning. Use a damp cloth; do not use liquid or aerosol cleaners.
- Never add any attachments and/or equipment without approval of the manufacturer. Such additions can increase the risk of fire, electric shock, or other personal injury.
- Do not use the TV receiver where contact with or immersion in water is a possibility, such as near bath tubs, sinks, washing machines, swimming pools, etc.
- Do not place the TV on an unstable cart, stand, tripod, bracket, or table where it can fall. A falling TV can cause serious injury to a child or adult, and serious damage to the appliance. Use only with a cart, stand, tripod, bracket, or table recommended by the manufacturer or sold with the TV. Follow the manufacturer's instructions when mounting the unit, and use a mounting accessory recommended by the manufacturer. Move the TV and cart with care. Quick stops, excessive force, and uneven surfaces can make the unit and cart unsteady and likely to overturn.
- Provide ventilation for the TV receiver. The unit is designed with slots in the cabinet for ventilation to protect it from overheating. Do not block these openings with any object, and do not place the TV receiver on a bed, sofa, rug, or other similar surface. Do not place it near a radiator or heat register. If you place the TV receiver on a rack or bookcase, ensure that there is adequate ventilation and that you've followed the manufacturer's instructions for mounting.
- Operate your TV receiver only from the type of power source indicated on the marking label. If you are not sure of the type of power supplied to your home, consult your appliance dealer or local power company.
- Use only a grounded or polarized outlet. For your safety, this TV is equipped with a polarized alternating current line plug having one blade wider than the other. This plug will fit into the power outlet only one way. If you are unable to insert the plug fully into the outlet, try reversing the plug. If the plug still does not fit, contact your electrician to replace your outlet.



- Protect the power cord. Power supply cords should be routed so that they won't be walked on or pinched by objects placed on or against them. Pay particular attention to cords at plugs, convenience receptacles, and the point where they exit from the unit.
- Unplug the TV from the wall outlet and disconnect the antenna or cable system during a lightning storm or when left unattended and unused for long periods of time. This will prevent damage to the unit due to lightning and power-line surges.
- Avoid overhead power lines. An outside antenna system should not be placed in the vicinity of overhead power lines or other electric light or power circuits or where it can fall into such power lines or circuits. When installing an outside antenna system, be extremely careful to keep from touching the power lines or circuits. Contact with such lines can be fatal.
- Do not overload the wall outlet or extension cords. Overloading can result in fire or electric shock.
- Do not insert anything through the openings in the unit, where they can touch dangerous voltage points or damage parts. Never spill liquid of any kind on the TV.
- Ground outdoor antennas. If an outside antenna or cable system is connected to the TV, be sure the antenna or cable system is grounded so as to provide some protection against voltage surges and built-up static charges. Section 810 of the National Electrical Code, ANSI/NFPA No.70-1984, provides information about proper grounding of the mast and supporting structure, grounding of the lead-in wire to an antenna discharge unit, size of grounding conductors, location of antenna discharge unit, connection to grounding electrodes, and requirements for the grounding electrode.

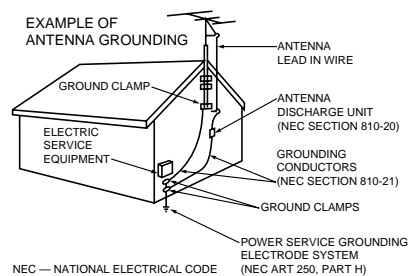

- Do not attempt to service the TV yourself. Refer all servicing to qualified service personnel. Unplug the unit from the wall outlet and refer servicing to qualified service personnel under the following conditions:
  - when the power-supply cord or plug is damaged
  - if liquid has been spilled on the unit or if objects have fallen into the unit
  - if the TV has been exposed to rain or water
  - if the TV does not operate normally by following the operating instructions
  - if the TV has been dropped or the cabinet has been damaged
  - when the TV exhibits a distinct change in performance
- If you make adjustments yourself, adjust only those controls that are covered by the operating instructions. Adjusting other controls may result in damage and will often require extensive work by a qualified technician to restore the TV to normal.
- When replacement parts are required, be sure the service technician uses replacement parts specified by the manufacturer or those that have the same characteristics as the original part. Unauthorized substitutions may result in additional damage to the unit.
- Upon completion of any service or repairs to this TV, ask the service technician to perform safety checks to determine that the TV is in a safe operating condition.

# CONTENTS

<b>Chapter 1: Your New TV</b> . . . . .	<b>1.1</b>
List of Features . . . . .	1.1
Familiarizing Yourself with The TV . . . . .	1.2
Front Panel Buttons . . . . .	1.2
Side Panel Jacks . . . . .	1.3
Rear Panel Jacks . . . . .	1.4
Remote Control . . . . .	1.5
<b>Chapter 2: Installation</b> . . . . .	<b>2.1</b>
Connecting VHF and UHF Antennas . . . . .	2.1
Antennas with 300-ohm Flat Twin Leads . . . . .	2.1
Antennas with 75-ohm Round Leads . . . . .	2.2
Separate VHF and UHF Antennas . . . . .	2.2
Connecting Cable TV . . . . .	2.2
Cable without a Cable Box . . . . .	2.2
Connecting to a Cable Box that Descrambles All Channels . . . . .	2.3
Connecting to a Cable Box that Descrambles some Channels . . . . .	2.3
Connecting a VCR . . . . .	2.4
Connecting an S-VHS VCR . . . . .	2.6
Connecting a Second VCR to Record from the TV . . . . .	2.7
Connecting a DVD Player . . . . .	2.7
Connecting a Camcorder . . . . .	2.8
Installing Batteries in the Remote Control . . . . .	2.9
<b>Chapter 3: Operation</b> . . . . .	<b>3.1</b>
Turning the TV On and Off . . . . .	3.1
Plug & Play Feature . . . . .	3.1
Viewing the Menus and On-Screen Displays . . . . .	3.3
Viewing the Menus . . . . .	3.3
Viewing the Display . . . . .	3.3
Selecting a Menu Language . . . . .	3.4
Memorizing the Channels . . . . .	3.5
Selecting the Video Signal-source . . . . .	3.5
Storing Channels in Memory (Automatic Method) . . . . .	3.6
Adding and Erasing Channels (Manual Method) . . . . .	3.7
Changing Channels . . . . .	3.8
Using the Channel Buttons . . . . .	3.8
Directly Accessing Channels . . . . .	3.8
Using the PRE-CH Button to select the Previous Channel . . . . .	3.8
Adjusting the Volume . . . . .	3.8
Using Mute . . . . .	3.8
Labeling the Channels . . . . .	3.9
Setting the Clock . . . . .	3.10
Customizing the Picture . . . . .	3.11
Using Automatic Picture Settings . . . . .	3.12
Customizing the Sound . . . . .	3.13
Using Automatic Sound Settings . . . . .	3.14
Setting The On/Off Melody . . . . .	3.15
Viewing a VCR or Camcorder Tape . . . . .	3.16

## CONTENTS

<b>Chapter 4: Special Features . . . . .</b>	<b>4.1</b>
Customizing Your Remote Control . . . . .	4.1
Setting Up Your Remote Control to Operate Your VCR. . . . .	4.1
Setting Up Your Remote Control to Operate Your Cable Box . . . . .	4.3
Fine Tuning Channels. . . . .	4.4
Digital Noise Reduction . . . . .	4.5
LNA (Low Noise Amplifier) . . . . .	4.6
Tilt . . . . .	4.7
Changing the Screen Size . . . . .	4.8
Using the R.Surf . . . . .	4.9
Setting the On/Off Timer . . . . .	4.10
Setting the Sleep Timer. . . . .	4.11
Sound Features. . . . .	4.12
Choosing a Multi-Channel Sound (MTS) Soundtrack. . . . .	4.12
Extra sound settings (Turbo Sound, Surround, Auto Volume or Virtual surround) . . . . .	4.13
Viewing Closed Captions . . . . .	4.14
Viewing Picture-in-Picture . . . . .	4.15
Activation Picture-in-Picture . . . . .	4.15
Selecting a Signal Source (External A/V) for PIP . . . . .	4.15
Changing the Size of the PIP Window . . . . .	4.15
Changing the Location (Rotating) the PIP Window . . . . .	4.16
Swapping the Contents of the PIP image and Main image . . . . .	4.16
Changing the PIP Channel . . . . .	4.16
Enjoying Games . . . . .	4.17
Viewing the Demonstration . . . . .	4.18
<b>Chapter 5: Troubleshooting . . . . .</b>	<b>5.1</b>
Identifying Problems . . . . .	5.1
<b>Appendix . . . . .</b>	<b>A.1</b>
Cleaning and Maintaining Your TV . . . . .	A.1
Using Your TV in Another Country . . . . .	A.1
Specifications . . . . .	A.1

# Chapter One

## YOUR NEW TV

### List of Features

Your TV was designed with the latest technology. This TV is a high-performance unit that includes the following special features:

- Easy-to-use remote control
- Easy-to-use on-screen menu system
- Automatic timer to turn the TV on and off
- Adjustable picture and sound settings that can be stored in the TV's memory
- Automatic channel tuning for up to 181 channels
- A special filter to reduce or eliminate reception problems
- Fine tuning control for the sharpest picture possible
- A built-in multi-channel sound decoder for stereo and bilingual listening
- Built-in, dual channel speakers
- A special sleep timer
- Headphone jack for private listening
- 16:9 letter box format available depending upon source
- Picture in Picture (For models CL-29A5P/CL-29A6P/CL-29A7P/CL-29M6P/CL-34M9P)

## Familiarizing Yourself with The TV

### Front Panel Buttons

The buttons on the front panel control your TV's basic features, including the on-screen menu. To use the more advanced features, you must use the remote control.

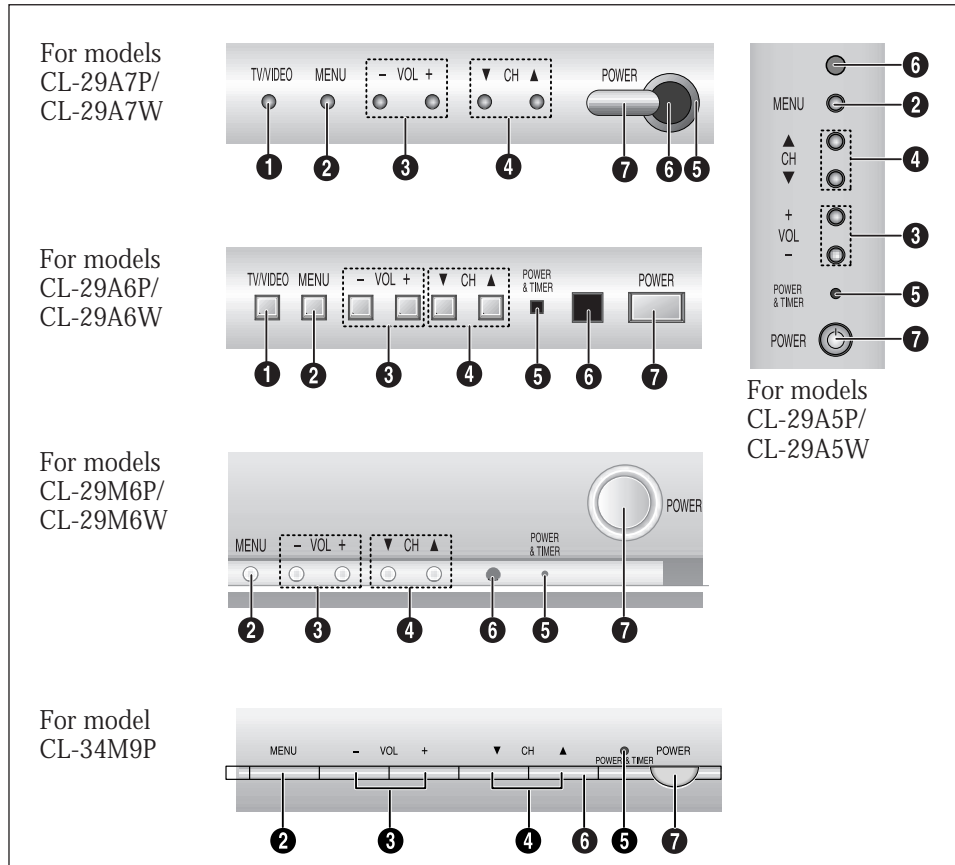

**1 TV/VIDEO**

Press to change between viewing TV programs and signals from other components.

**2 MENU**

Press to see an on-screen menu of your TV's features.

**3 VOLUME - , +**

Press to increase or decrease the volume. Also used to select items on the on-screen menu.

**4 CH ▼ and CH ▲**

Press to change channels. Also press to highlight various items on the on-screen menu.

**5 POWER & TIMER indicator**

When the TV is turned on, the POWER & TIMER indicator blinks ten times. This indicator illuminates when the TIMER mode is set to the "On" position after setting the clock and either the On timer or Off timer, with the remote control. Even if the power is turned off, this indicator stays lit. (Clock must be set before using this function.)

**6 Remote Control Sensor**

Aim the remote control towards this spot on the TV.

**7 POWER**

Press to turn the TV on and off.



## YOUR NEW TV

### Side Panel Jacks

You can use the Side panel jacks to connect an A/V component that is used only occasionally, such as a camcorder or video game. (For information on connecting equipment, see pages 2.1 – 2.8.)

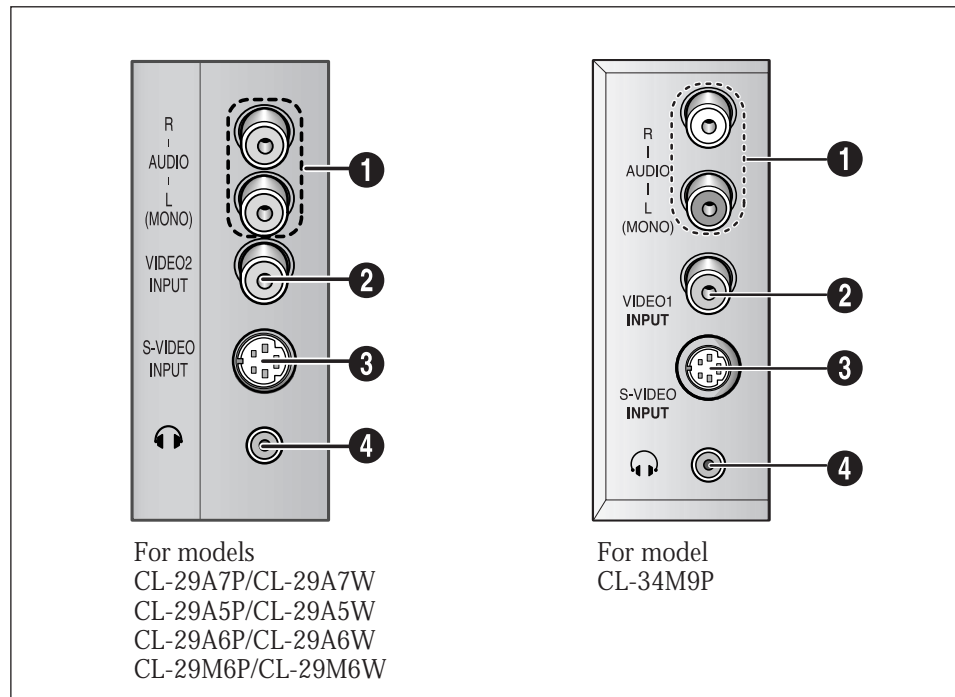

**1 AUDIO INPUT jacks**

Used to connect the audio signals from a camcorder or video game.

**2 VIDEO INPUT jack**

Used to connect a video signal from a camcorder or a video game.

**3 S-VIDEO INPUT jack**

Used to connect an S-Video signal from a camcorder or a video game.

**4 HEADPHONE jack**

Connect a set of external headphones to this jack for private listening.

## YOUR NEW TV

### Rear Panel Jacks

Use the rear panel jacks to connect an A/V component that will be connected continuously, such as a VCR or a laserdisc player. Because there are two sets of input jacks, you can connect two different A/V components (i.e., a VCR and a laserdisc, 2 VCRs, etc.)

For more information on connecting equipment, see pages 2.1 – 2.8.

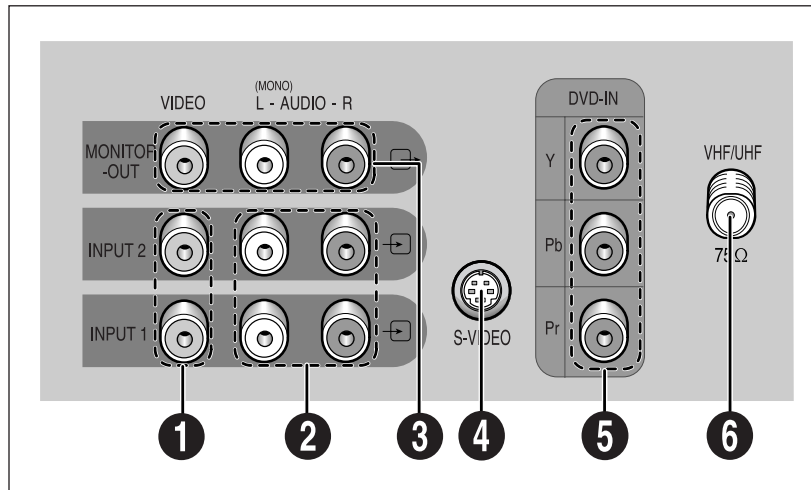

**1 VIDEO INPUT jack**

Video signals from VCRs, laserdisc players and similar devices.

**2 AUDIO INPUTS (INPUT 1 and 2) / DVD AUDIO INPUTS (INPUT 2)**

Audio signals from VCRs, laserdisc players and similar devices.

Use these jacks to connect the audio signals from a DVD player when using the DVD video input jacks. When not using the DVD jacks, these audio jacks function as audio for Video 2 or S-VIDEO).

**3 AUDIO-VIDEO MONITOR OUTPUT jacks**

These audio-video signals are identical to A/V signals being displayed on the big screen. (Typically used as the input signals for a recoding VCR.)

**4 SUPER VIDEO INPUT jack**

S-Video signal from an S-VHS VCR or laserdisc player.

**5 DVD VIDEO INPUT jacks**

Connect video from a DVD player.

Note: Only black and white signals are output from a monitor in DVD mode.

**6 VHF/UHF**

Connect to an antenna or to a cable TV system.

# YOUR NEW TV

## Remote Control

You can use the remote control up to about 23 feet from the TV. When using the remote, always point it directly at the TV.

You can also use your remote control to operate your VCR and cable box. See page 4.1 for details.

### 1 POWER

Turns the TV on and off.

### 2 Number buttons

Press to select channels directly on the TV.

#### +100

Press to select channels over 100. For example, to select channel 121, press "+100," then press "2" and "1."

### 3 P.SIZE

Press to change to screen size. Your choices are Normal screen, Zoom screen or Wide screen.

### 4 R.SURF

Press the R.SURF button to automatically return to a preferred channel after a user-preset time delay.

### 5 SLEEP

Press to select a preset time interval for automatic shutoff.

### 6 TURBO

Press to select the TURBO sound On or Off.

### 7 MUTE

Press to temporarily cut off the sound.

### 8 CH▲ and CH▼ (Channel Up/Down)

Press CH▲ or CH▼ to change channels. (Also used to highlight selections on the on-screen menus.)

### 9 P.STD

Adjust the TV picture by selecting one of the preset factory settings (or select your personal, customized picture settings).

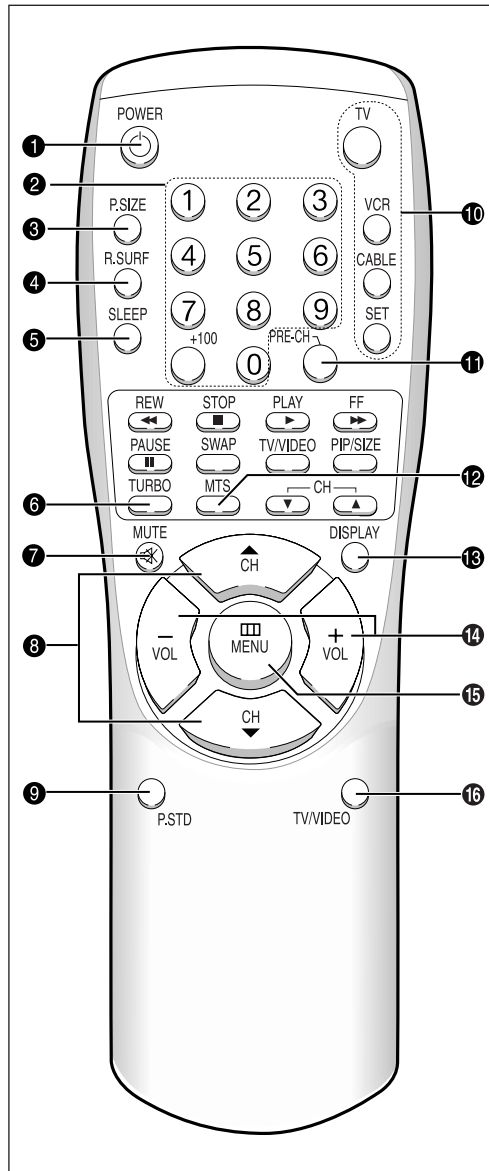

### 10 TV

Press to use your remote control to operate your TV.

### VCR

Press to use your remote control to operate your VCR.

### CABLE

Press to use your remote control to operate a CABLE BOX.

### SET

Use this button when you are setting up your remote control to operate your VCR or Cable box.

### 11 PRE-CH

Tunes to the previous channel.

### 12 MTS (Multichannel Television Stereo)

Press to choose stereo, mono or Separate Audio Program (SAP broadcast).

### 13 DISPLAY

Press to see the time, channel, etc., on-screen. Also press to exit (quit) the menu system.

### 14 VOL -, VOL +

Press increase or decrease the volume. (Also used to make selections on the on-screen menus.)

### 15 MENU

Displays the main on-screen menu.

### 16 TV/VIDEO

Press to display all of the available video sources (i.e., Antenna/cable, VCR, DVD).

# YOUR NEW TV

## Remote Control

### 17 VCR controls

#### **REW (Rewind)**

Press to rewind a tape.

#### **STOP**

Press to stop a tape in your VCR.

#### **PLAY**

Press to play the tape.

#### **FF (Fast Forward)**

Press to fast forward a tape.

#### **PAUSE**

Press to play or pause the tape.

### 18 PIP Controls

(For models CL-29A5P/CL-29A6P/  
CL-29A7P/CL-29M6P/CL-34M9P)

#### **SWAP**

Exchanges the video signal that is currently displayed on the main screen with the signal in the PIP window.

#### **TV/VIDEO**

Press to select one of the available signal sources for the PIP window.

#### **PIP/SIZE**

Press this button to control the PIP window. Press repeatedly to cycle through this sequence: PIP ON with large window, PIP ON with small window, and PIP OFF.

#### **CH**

Displays the available channels in sequence. (These buttons change channels in the PIP window only).

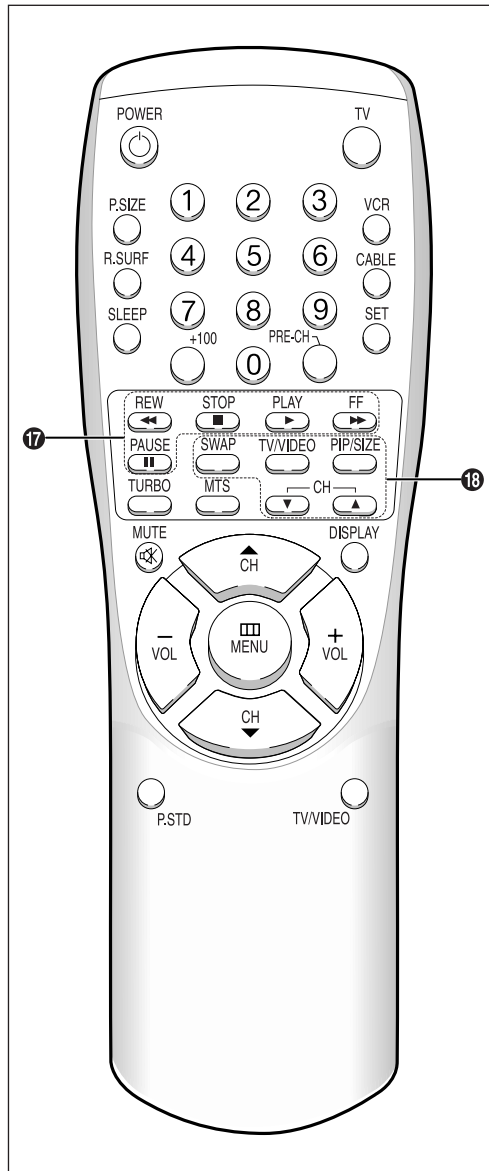

# Chapter Two

## INSTALLATION

### Connecting VHF and UHF Antennas

If your antenna has a set of leads that look like this, see “Antennas with 300-ohm Flat Twin Leads,” below.



If your antenna has one lead that looks like this, see “Antennas with 75-ohm Round Leads,” on page 2.2.



If you have two antennas, see “Separate VHF and UHF Antennas,” on page 2.2.

#### Antennas with 300-ohm Flat Twin Leads

If you are using an off-air antenna (such as a roof antenna or “rabbit ears”) that has 300-ohm twin flat leads, follow the directions below.

**1**

Place the wires from the twin leads under the screws on the 300-75 ohm adaptor (not supplied). Use a screwdriver to tighten the screws.

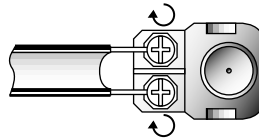

**2**

Plug the adaptor into the VHF/UHF terminal on the bottom of the back panel.

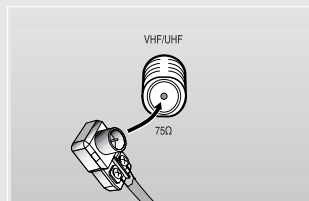

## INSTALLATION

### Antennas with 75-ohm Round Leads

**1**

Plug the antenna lead into the VHF/UHF terminal on the bottom of the back panel.

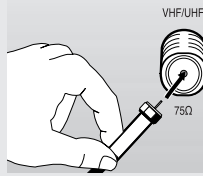

### Separate VHF and UHF Antennas

If you have two separate antennas for your TV (one VHF and one UHF), you must combine the two antenna signals before connecting the antennas to the TV. This procedure requires a an optional combiner-adaptor (available at most electronics shops).

**1**

Connect both antenna leads to the combiner.

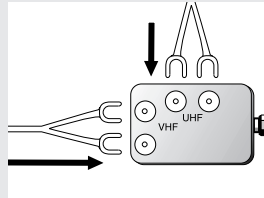

**2**

Plug the combiner into the VHF/UHF terminal on the bottom of the rear panel.

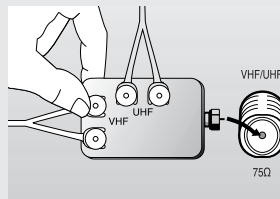

### Connecting Cable TV

To connect to a cable TV system, follow the instructions below.

#### Cable without a Cable Box

**1**

Plug the incoming cable into the VHF/UHF antenna terminal on back of the TV.



◀ Because this TV is cable-ready, you do not need a cable box to view unscrambled cable channels.

## INSTALLATION

### Connecting to a Cable Box that Descrambles All Channels

**1**

Find the cable that is connected to the ANTENNA OUT terminal on your cable box.

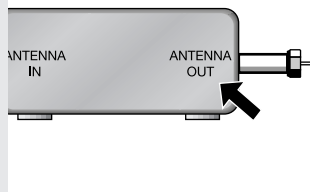

◀ This terminal might be labeled “ANT OUT,” “VHF OUT,” or simply, “OUT.”

**2**

Connect the other end of this cable to the VHF/UHF antenna terminal on the back of the TV.

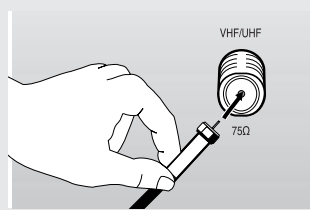

### Connecting to a Cable Box that Descrambles Some Channels

If your cable box descrambles only some channels (such as premium channels), follow the instructions below. You will need a two-way splitter, an RF (A/B) switch, and four lengths of coaxial cable. (These items are available at most electronics stores.)

**1**

Find and disconnect the cable that is connected to the ANTENNA IN terminal on your cable box.

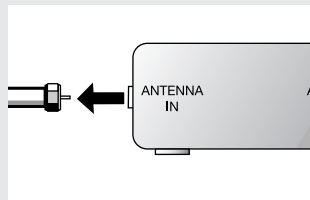

◀ This terminal might be labeled “ANT IN,” “VHF IN,” or simply, “IN.”

**2**

Connect this cable to a two-way splitter.

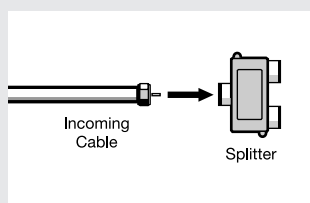

**3**

Connect a coaxial cable between an OUTPUT terminal on the splitter and the IN terminal on the cable box.

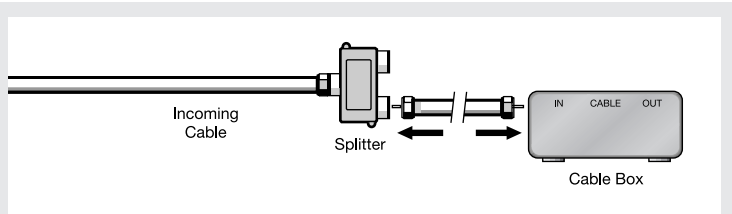

## INSTALLATION

**4**

Connect a coaxial cable between the ANTENNA OUT terminal on the cable box and the B-IN terminal on the A/B switch.

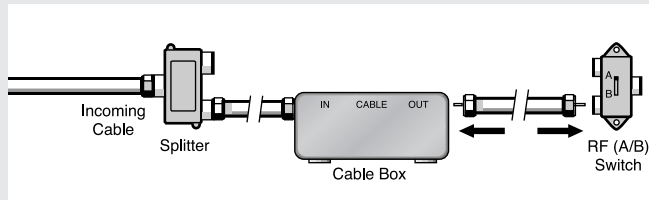

**5**

Connect another cable between the other OUT terminal on the splitter and the A-IN terminal on the RF (A/B) switch.

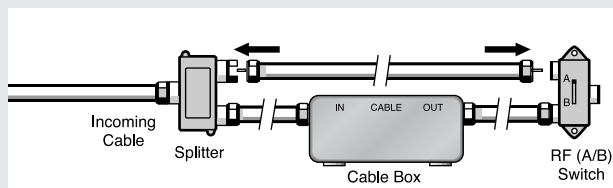

**6**

Connect the last coaxial cable between the OUT terminal on the RF (A/B) switch and the VHF/UHF terminal on the rear of the TV.

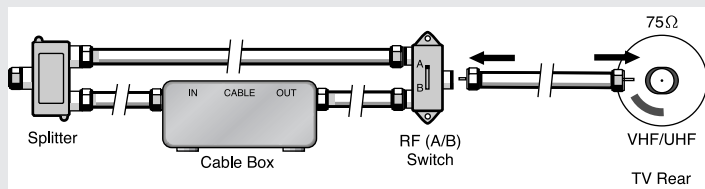

After you've made this connection, set the A/B switch to the "A" position for normal viewing. Set the A/B switch to the "B" position to view scrambled channels. (When you set the A/B switch to "B," you will need to tune your TV to the cable box's output channel, which is usually channel 3 or 4.)

## Connecting a VCR

These instructions assume that you have already connected your TV to an antenna or a cable TV system (according to the instructions on pages 2.1-2.3). Skip step 1 if you have not yet connected to an antenna or a cable system.

**1**

Unplug the cable or antenna from the back of the TV.

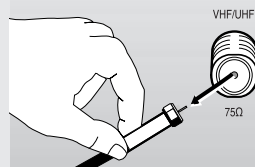

**2**

Connect the cable or antenna to the ANTENNA IN terminal on the back of the VCR.

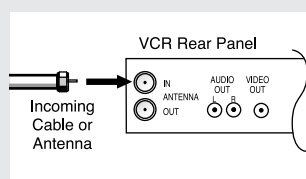



## INSTALLATION

**3**

Connect a coaxial cable between the ANTENNA OUT terminal on the VCR and the antenna terminal on the TV.

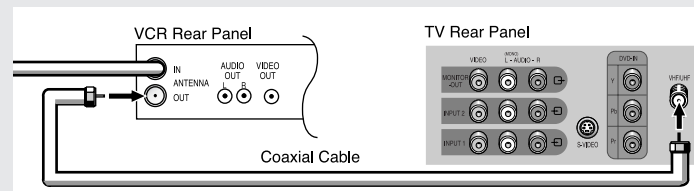

A coaxial cable is usually included with a VCR. (If not, check your local electronics store).

**4**

Connect a set of audio cables between the AUDIO OUT jacks on the VCR and the AUDIO jacks on the TV.

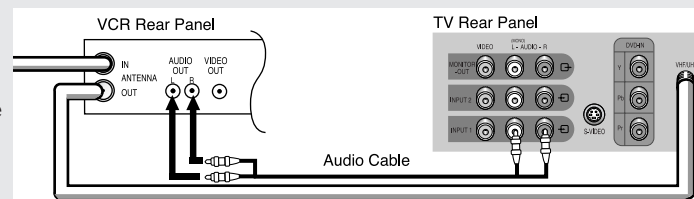

If you have a “mono” (non-stereo) VCR, use the Y-connector (not supplied) to hook up to the left and right audio input jacks of the TV. If your VCR is stereo, you must connect two cables.

**5**

Connect a video cable between the VIDEO OUT jack on the VCR and the VIDEO jack on the TV.

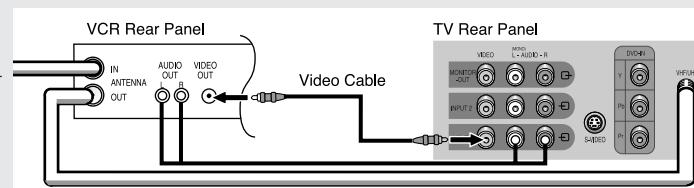

Follow the instructions in “Viewing a VCR or Camcorder Tape” to view your VCR tape.

## INSTALLATION

### Connecting an S-VHS VCR

Your Samsung TV can be connected to an S-Video signal from an S-VHS VCR. (This connection delivers a better picture as compared to a standard VHS VCR.)

#### 1

To begin, follow steps 1–3 in the previous section to connect the antenna or cable to your VCR and your TV.

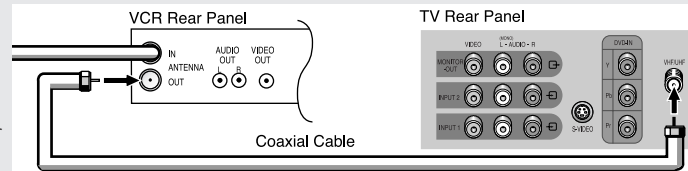

#### 2

Connect a set of audio cables between the AUDIO OUT jacks on the VCR and the 2 AUDIO INPUT jacks on the TV.

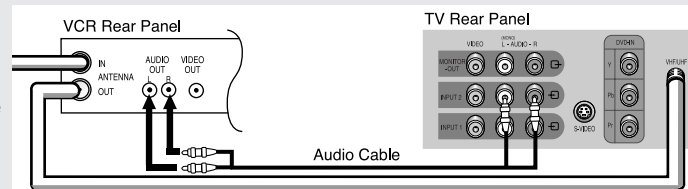

Make sure the jacks you are using are underneath the number “2.”

#### 3

Connect an S-video cable between the S-VIDEO OUT jack on the VCR and the S-VIDEO INPUT jack on the TV.

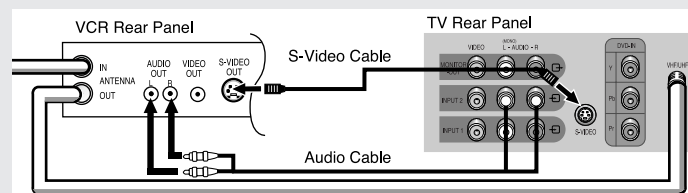

An S-video cable is usually included with an S-VHS VCR. (If not, check your local electronics store.)

## INSTALLATION

### Connecting a Second VCR to Record from the TV

Your TV can send out signals of its picture and sound to be recorded by a second VCR. To do this, connect your second VCR as follows:

**1**

Connect a set of audio cables between the AUDIO OUT jacks on the TV and the AUDIO IN jacks on the VCR.

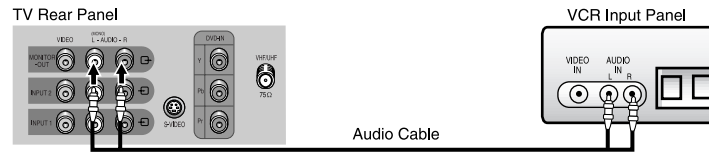

(The VCR input jacks might be either on the front or on back of the VCR.)

**2**

Connect a video cable between the VIDEO OUT jack on the TV and the VIDEO IN jack on the VCR.

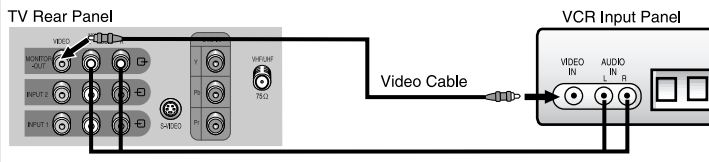

Refer to your VCR's instructions for more information about how to record using this kind of connection.

### Connecting a DVD Player

The rear panel jacks on your TV make it easy to connect a DVD player to your TV.

**1**

Connect a set of audio cables between the AUDIO INPUT 2 jacks on the TV and the AUDIO OUT jacks on the DVD player.

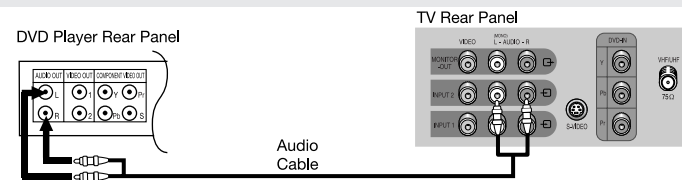

**2**

Connect a video cable between the DVD-IN (Y, Pb, Pr) jacks on the TV and the DVD-OUT (Y, Pb, Pr) jacks on the DVD player.

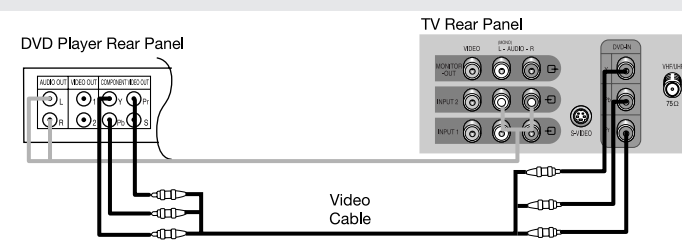

To enable DVD viewing, connect video cables between the Y, Pb and Pr inputs on the TV and Y, Pb and Pr outputs on the DVD player.

Note: For an explanation of Component video, see your DVD player's owner's manual.

## INSTALLATION

### Connecting a Camcorder

The side panel jacks on your TV make it easy to connect a camcorder to your TV. They allow you to view the camcorder tapes without using a VCR. (Also see “Viewing a VCR or Camcorder Tape” on page 3.16)

**1**

Locate the A/V output jacks on the camcorder. They are usually found on the side or back of the camcorder.

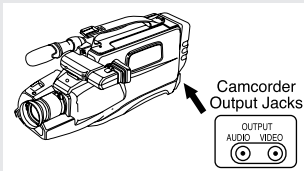

**2**

Connect an audio cable between the AUDIO OUTPUT jack on the camcorder and the AUDIO terminals on the side of the TV.

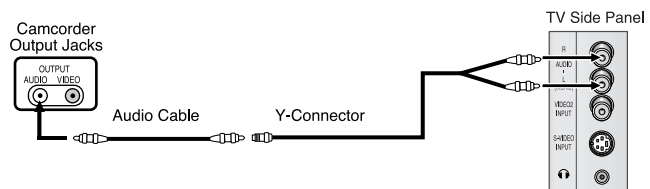

**3**

Connect a video cable between the VIDEO OUTPUT jack on the camcorder and the VIDEO terminal on the side of the TV.

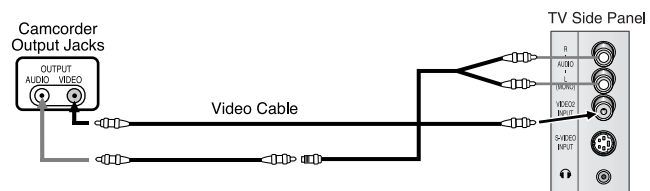

The audio-video cables shown here are usually included with a Camcorder. (If not, check your local electronics store.) If your camcorder is stereo, you need to connect a set of two cables.

## INSTALLATION

### Installing Batteries in the Remote Control

**1**

Slide the cover out completely.

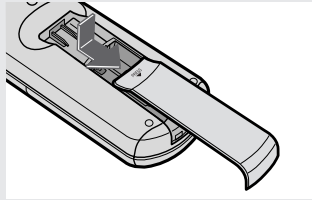

**2**

Install two AA size batteries.

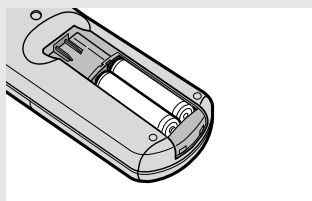

◀ Make sure to match the “+” and “-” ends of the batteries with the diagram inside the compartment.

**3**

Replace the cover.

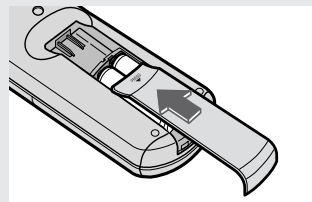

◀ Remove the batteries and store them in a cool, dry place if you won't be using the remote control for a long time.

The remote control can be used up to about 23 feet from the TV.

(Assuming typical TV usage, the Batteries last for about one year.)

# Chapter Three

## OPERATION

### Turning the TV On and Off

Press **POWER**.

You can also use the **POWER** button on the front panel.

### Plug & Play Feature

When the TV is initially powered On, five basic customer settings proceed automatically and subsequently: Setting the language, video signal source, Ant. input check, Auto program, and Clock.

#### 1

Press **POWER** button on the remote control.

The message "Plug & Play" is displayed. It flickers for a little while and then the "Language" menu is automatically displayed.



#### 2

Press **VOL+** or **VOL-** to select required language. Press **MENU** to enter the language, and then the "Channel" menu is automatically displayed.

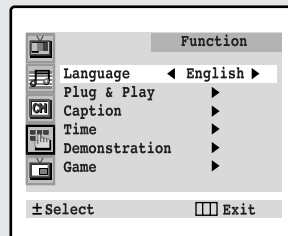

#### 3

Press **VOL+** or **VOL-** to select required video signal source. Press **MENU** to enter the video signal source, and then the "Ant. Input check" automatically displayed.

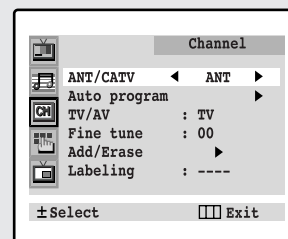

*continued...*

## OPERATION

### 4

Make sure that the antenna is connected to the TV. And then press **VOL+** or **VOL-**. The "Auto Program" is active. Press **MENU** to skip. (refer to "Auto program" on page 3.6.)

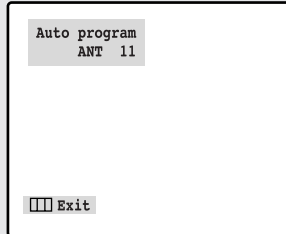

### 5

Press **VOL+** or **VOL-** to move to the hour or minute. Set the hour or minute by pressing the **CH▲** or **CH▼**. (refer to "Setting the clock" on page 3.10.)

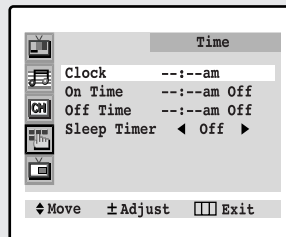

### 6

When you have finished, press **MENU** button. The message "Enjoy your watching" is displayed.

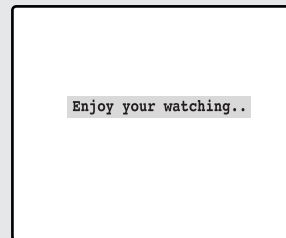

### 7

**If you want to reset this feature**

- (1) Press **MENU** button.
- (2) Press **CH▼** three times to select the Function menu and press **VOL+**.
- (3) Press **CH▼** to select the Plug & Play and press **VOL+**. The message "Plug & Play" is displayed.

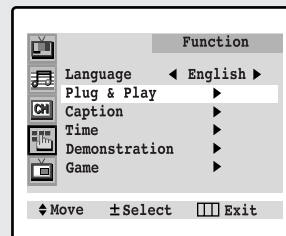

Note: Plug & Play feature doesn't work in the A/V mode.

## Viewing the Menus and On-Screen Displays

### Viewing the Menus

#### 1

With the power on, press **MENU**.

The main menu appears on the screen. Its left side has five icons: Picture, Sound, Channel, Function and PIP.

For models CL-29A5P/CL-29A6P/  
CL-29A7P/CL-29M6P/CL-34M9P

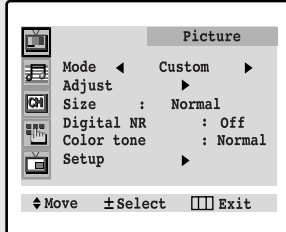

For models CL-29A5W/CL-29A6W/  
CL-29A7W/CL-29M6W

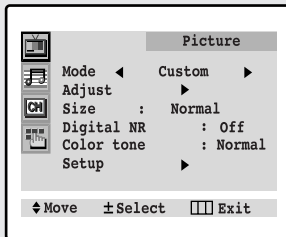

◀ The on-screen menus disappear from the screen after thirty seconds.

The main screen shows differently according as model has PIP feature.

#### 2

Use the **CH▲** and **CH▼** buttons to highlight one of the 5 (or 4) icons. Then press **VOL+** to access the icon's sub-menu.

#### 3

Press **MENU** to exit.

◀ You can also use the **MENU**, **CHANNEL**, and **VOLUME** buttons on the control panel of the TV to make selections.

### Viewing the Display

#### 1

Press the **DISPLAY** on the remote control.

The on-screen display shows any or all of the following: Active channel, the channel label, video source, the time, and the time remaining on the sleep timer.

("\*" indicates a channel has been manually fine tuned.)

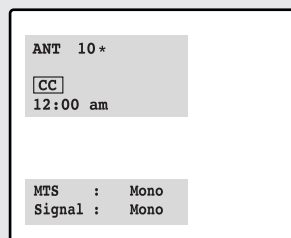

◀ The on-screen displays disappear after about ten seconds.



## OPERATION

### Selecting a Menu Language

**1**

Press **MENU** to display the menu.

Press **CH** ▼ three times to select “Function.”

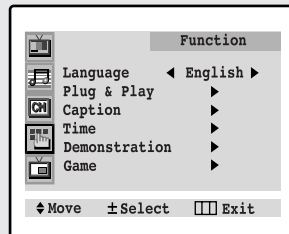

**2**

Press **VOL +** to display the “Function” menu.

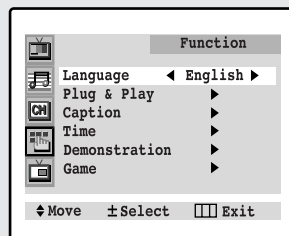

**3**

Press **VOL +** to select the appropriate language: English, Spanish, or Portuguese.

**4**

Press **MENU** twice to exit.

## Memorizing the Channels

Your TV can memorize and store all of the available channels for both “off-air” (antenna) and cable channels. After the available channels are memorized, use the CH ▲ and CH ▼ buttons to scan through the channels. This eliminates the need to change channels by entering the channel digits. There are three steps for memorizing channels: selecting a broadcast source, memorizing the channels (automatic) and adding and deleting channels (manual).

### Selecting the Video Signal-source

Before your television can begin memorizing the available channels, you must specify the type of signal source that is connected to the TV (i.e., an antenna or a cable system).

**1**

Press **MENU** to display the menu.

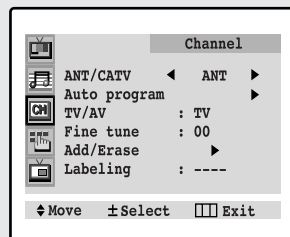

**2**

Press **CH ▼** two times to select “Channel.”

**3**

Press **VOL +**.  
The first line of the menu is selected.

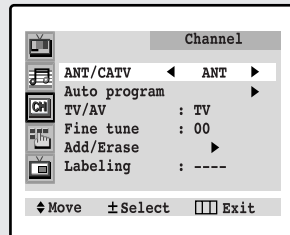

**4**

Repeatedly press **VOL +** to cycle through these choices:  
ANT (antenna)  
STD, HRC or IRC (all cable TV).

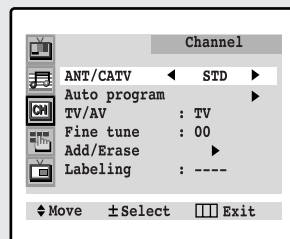

Note: STD, HRC and IRC identify various types of cable TV systems. Contact your local cable company to identify the type of cable system that exists in your particular area.

At this point the signal source has been selected. Proceed to “Storing Channels in Memory” (next page).

## OPERATION

### Storing Channels in Memory (Automatic Method)

#### 1

First, select the correct signal source (ANT, STD, HRC, IRC). See steps 1-4 on previous page.

Press **MENU**, then press **CH** ▼ twice to select "Channel."

Press **VOL +** to access the Channel sub-menu.

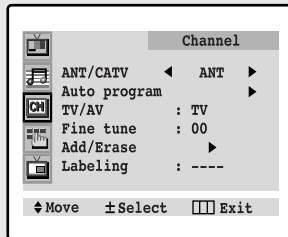

#### 2

Press **CH** ▼ to select "Auto program".

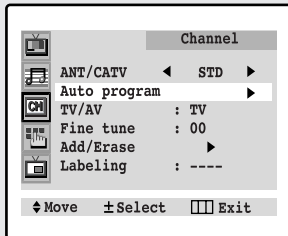

#### 3

Press **VOL +**. The TV will begin memorizing all of the available channels.

#### 4

After all the available channels are stored, the Auto program menu reappears. Press **MENU** twice to exit.

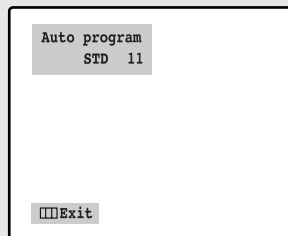

◀ The TV automatically cycles through all of the available channels and stores them in memory. This takes about one to two minutes. Press **MENU** at any time to interrupt the memorization process and return to the Channel menu.

## OPERATION

### Adding and Erasing Channels (Manual Method)

**1**

Press **MENU**, then press **CH ▼** twice to select "Channel".  
Press **VOL+** to access the channel sub-menu.

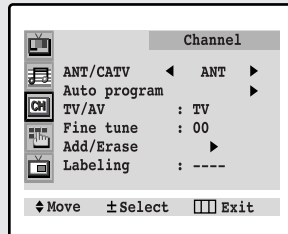

**2**

Press **CH ▲** or **CH ▼** to select "Add/Erase".

Press **VOL+**.

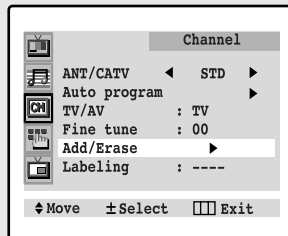

**3**

Press **VOL+**.

Press **CH ▲/▼** or number button to select the channel you want to added or erased.

Press **MENU**.

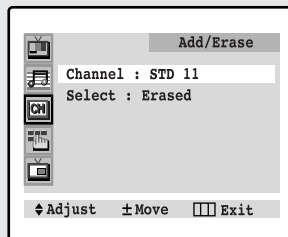

**4**

Press **CH ▲** or **CH ▼** to select "Select".

Press **VOL+** or **VOL-** to select "Added" or "Erased".

Press **MENU** three times to exit.

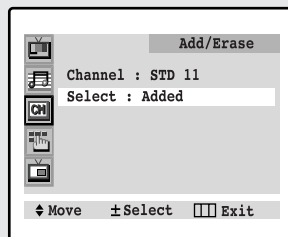

## Changing Channels

### Using the Channel Buttons

#### 1

Press the **CH ▲** or **CH ▼** button to change channels.

When you press **CH ▲** or **CH ▼**, the TV changes channels in sequence. You will see all the channels that the TV has memorized. (The TV must have memorized at least three channels.) You will not see channels that were either erased or not memorized.

### Directly Accessing Channels

Use the number buttons to quickly tune to any channel.

#### 1

Press the number buttons to go directly to a channel. For example, to select channel 27, press “2,” then “7.” The TV will change channels when you press the second number.

When you use the number buttons, you can directly select channels that were either erased or not memorized.

To select a channel over 100, press the **+100** button. (For channel 122, press “+100,” then “2,” then “2.”)

To change to single-digit channels (0–9) faster, press “0” before the single digit. (For channel “4,” press “0,” then “4.”)

### Using the PRE-CH Button to select the Previous Channel

#### 1

Press **PRE-CH**.  
The TV will switch to the last channel viewed.

◀ To quickly switch between two channels that are far apart, tune to one channel, then use the number button to select the second channel. Then, use the **PRE-CH** button to quickly alternate between them.

## Adjusting the Volume

Press **VOL +** or **– VOL** to increase or decrease the volume.

### Using Mute

At any time, you can temporarily cut off the sound using the Mute button.

#### 1

Press **MUTE** and the sound cuts off. The word “Mute” will appear in the lower-left corner of the screen.

#### 2

To turn mute off, press **MUTE** again, or simply press either the **VOL –** or **VOL +** button.

## Labeling the Channels

Use this feature to assign an easy-to-remember label to any channel (i.e., “CBS”, “ESPN”, “PBS2”, CNN1”, etc.) A label consists of four fields, where each field is a letter, a number, “\*”, or a blank. When the DISPLAY button is pressed, the channel label will appear next to the channel number.

- 1**  
Press **CH ▲** or **CH ▼** to tune to the channel that will be labeled.

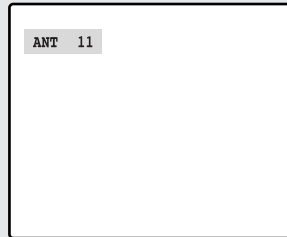

- 2**  
Press **MENU** to display the menu.

Press **CH ▼** twice to select “Channel”.

Press **VOL +**.

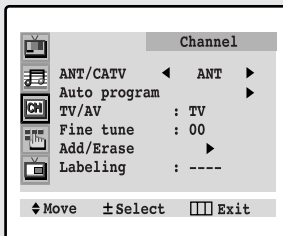

◀ Note: You cannot select “Labeling” in the A/V mode.

- 3**  
Press **CH ▼** five times to select “Labeling”.

Press **VOL +** to begin labeling. The left-most field will be high-light. (Each label has four fields. See top paragraph.)

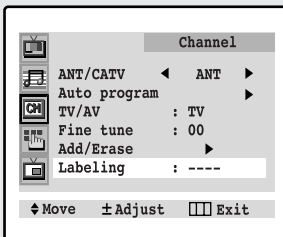

- 4**  
Press the **CH ▲** or **CH ▼** button to select a letter, a number, “\*”, or a blank. (Pressing **CH ▲** results in this sequence: A,B,...Z,\*, blank,0,1,...9).

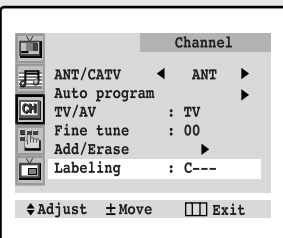

- 5**  
Press **VOL+** to switch to the next field, which will be high-light. Select a second letter or digit using the **CH ▲** and **CH ▼** buttons, as above. Repeat the process to select the last two digits.

Press **MENU** twice to set the label and clear the menus from the screen.

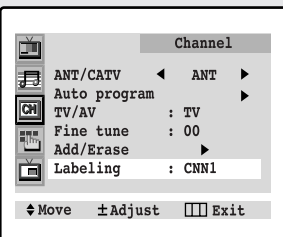

## OPERATION

### Setting the Clock

#### 1

Press the **MENU** button to display the on-screen menu.

Press **CH ▼** three times to select "Function."  
Press **VOL +**.

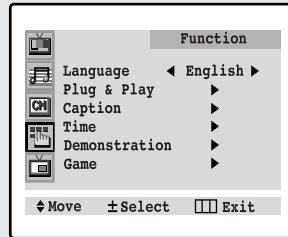

#### 2

Press **CH ▼** three times to select Time menu.

Press **VOL +**: The Time menu will appear on the screen, and "Clock" will be highlighted (blue color).

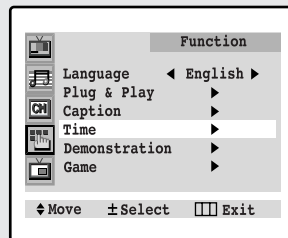

#### 3

Press **VOL +** again (the hours digits will be highlighted). Press **CH ▲** or **CH ▼** repeatedly until the correct hour appears.

After the hour is entered, press **VOL +**. (at this point the minutes digits will be highlighted).

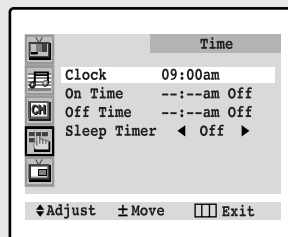

#### 4

Press the **CH ▲** or **CH ▼** button to select the correct minutes.

After selecting the correct minutes, press **VOL +**.

Press **MENU** three times to exit.

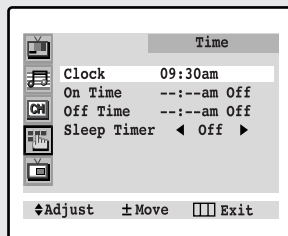

◀ When selecting the hours, be sure to select the proper time of day (AM or PM).

You can change the hours by pressing **CH ▲** or **CH ▼** repeatedly (or by holding down either of these buttons).

◀ The time will appear every time you press DISPLAY.

## Customizing the Picture

You can use the on-screen menus to change the contrast, brightness, tint, color, and sharpness according to personal preference. (Alternatively, you can use one of the “automatic” settings. See next page.)

- 1**  
Press **MENU** to display menu.

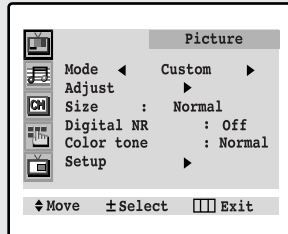

- 2**  
Press **VOL -** or **VOL +** repeatedly, until the word “Custom” is selected. (When Custom is highlighted, the words “Adjust” will appear on the screen.)

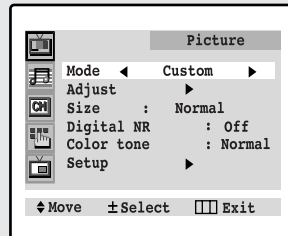

◀ The customer can select “Normal”, “Warm”, or “Cool” according to personal preference.

- 3**  
Press **CH ▼** to select a “Adjust”, then press **VOL+**. (The words Contrast, Brightness, Sharpness, Color, and Tint will appear on the screen.)  
Press **CH ▲** or **CH ▼** to select a particular item.

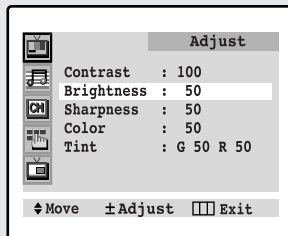

◀ There is no Tint in PAL System.

- 4**  
Press **VOL -** or **VOL +** to increase or decrease the value of a particular item. For example, if you select “Brightness,” pressing **VOL +** increases it.

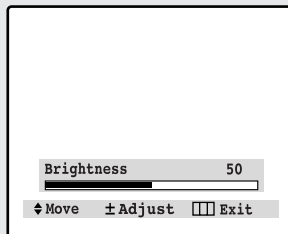

- Press **MENU** four times to exit.

◀ After adjusting an item, the gauge will automatically disappear (after about 5 seconds).



## Using Automatic Picture Settings

Your Samsung TV has three automatic picture settings (“Standard”, “Natural”, and “Mild”) that are preset at the factory. You can activate either Standard or Mild by making a selection from the menu). Or, you can select “Custom” which automatically recalls your personalized picture settings.

### 1

Press **MENU** to display the menu.

Press **VOL +**.

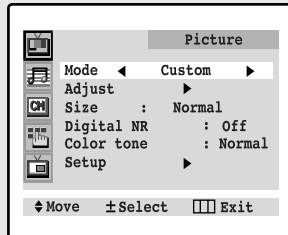

### 2

Press **VOL -** or **VOL +** to select the “Standard,” “Natural,” “Mild,” or “Custom” picture setting.

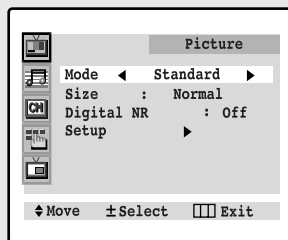

- Choose *Standard* for the standard factory settings.
- Natural: Optimal indoor screen condition.
- Choose *Mild* (“Mild Contrast”) when viewing the TV in low light, or when playing video games.
- Choose *Custom* if you want to adjust the settings according to personal preference (see “Customizing the Picture, page 3.11).

## Customizing the Sound

You can use the on-screen menus to adjust the bass, treble, and balance according to individual preference. (Alternatively, you can use one of the “automatic” settings. See next page.)

**1**

Press **MENU** to display the menu.

Press **CH ▼** to select “Sound” menu.

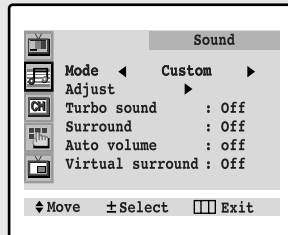

**2**

Press **VOL -** or **VOL +** repeatedly, until the word “Custom” is selected. (When Custom is selected, the words “Adjust” will appear on the screen.)

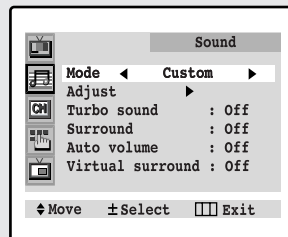

**3**

Press **CH ▼** to select “Adjust”, then press **VOL+**. (The words Bass, Treble, and Balance will appear on the screen.)

Press the **CH ▲** or **CH ▼** to select a particular item to be changed.

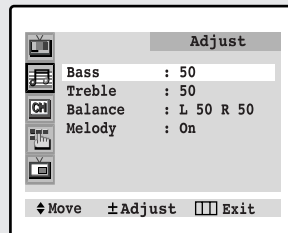

**4**

Press **VOL -** or **VOL +** to increase or decrease the value of a particular item. For example, if you select “Bass,” pressing **VOL +** increases it.

Press **MENU** three times to exit.

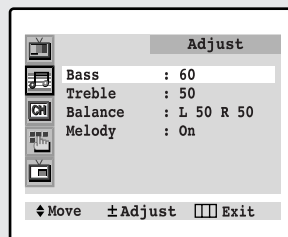

## Using Automatic Sound Settings

Your TV has four automatic sound settings (“Standard,” “Music,” “Movie,” and “Speech”) that are preset at the factory. You can activate any of them by making a selection from the on-screen menu. Or, you can select “Custom,” which automatically recalls your personalized sound settings.

### 1

Press **MENU** to display the menu.

Press **CH** once to select “Sound” menu.

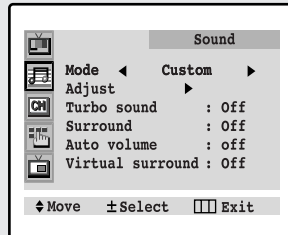

### 2

Press **VOL -** or **VOL +** repeatedly to select the “Standard,” “Music,” “Movie,” “Speech” or “Custom” sound settings.

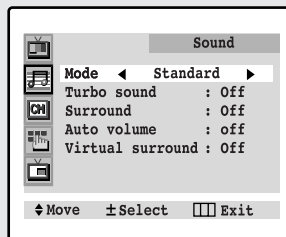

- Choose *Standard* for the standard factory settings.
- Choose *Music* when watching music videos or concerts.
- Choose *Movies* when watching movies.
- Choose *Speech* when watching a show that is mostly dialogue (i.e., news).
- Choose *Custom* to recall your personalized settings.

## Setting The On/Off Melody

You can hear clear melody sound when the TV is powered on or Off.

**1**

Press **MENU** to display the menu.

Press **CH** ▼ to select "Sound" menu.

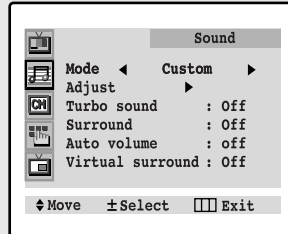

**2**

Press **VOL -** or **VOL +** repeatedly, until the word "Custom" is selected. (When Custom is selected, the words "Adjust" will appear on the screen.)

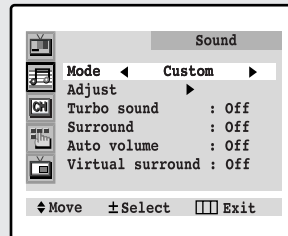

**3**

Press **CH** ▼ to select "Adjust", then press **VOL+**.

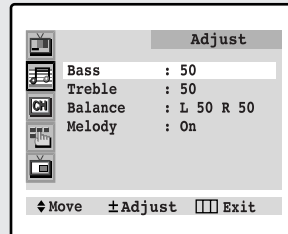

**4**

Press **CH** ▼ to select "Melody", then press **VOL+** or **VOL-** to select the "On" or "Off".

Press **MENU** three times to exit.

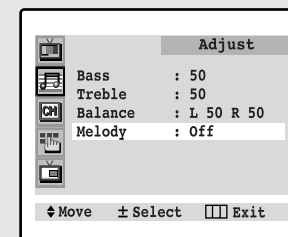

## OPERATION

### Viewing a VCR or Camcorder Tape

You must select the appropriate mode in order to view the VCR or Camcorder signal on the TV.

#### 1

Press **MENU** to display the menu.

Press **CH** ▼ twice to select "Channel", then press **VOL+**.

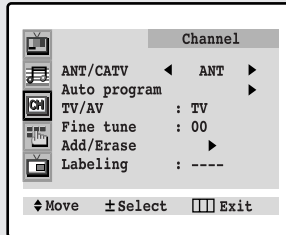

#### 2

Press **CH** ▼ twice to select "TV/AV".

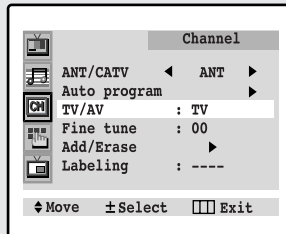

#### 3

Press **VOL+** or **VOL-**. You will switch between viewing the signals coming from equipment connected to the TV's A/V jacks, and the TV signal.

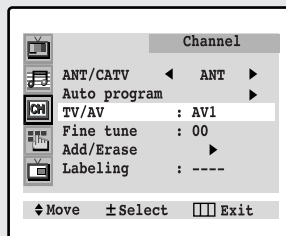

# Chapter Four

## SPECIAL FEATURES

### Customizing Your Remote Control

Your TV comes equipped with a “universal” remote control. In addition to controlling the TV, the universal remote can also operate a VCR and a cable box (even if your VCR and cable box are made by manufacturers other than Samsung).

#### Setting Up Your Remote Control to Operate Your VCR

**1**

Turn off your VCR.

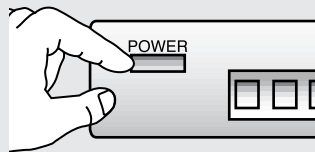

**2**

On your Samsung remote control, press **SET**.

**3**

Press the **VCR** button on the top right of your remote control.

**4**

Enter both digits of the VCR code listed on the next page for your brand of VCR.

**5**

Press the **POWER** button on the remote control. Your VCR should turn on. If your VCR turns on, your remote control is now set correctly.

**6**

Once your remote control is set up, press the **VCR** button any time you want to use the remote to operate your VCR.

◀ The remote control has three “modes”: “TV,” “VCR,” and “Cable” Press the “VCR” button to switch the remote control to the “VCR” mode.

◀ Make sure you enter both digits of the code, even if the first digit is a “0.” If more than one code listed, try the first one.

◀ If your VCR does not turn on, repeat steps 2, 3, and 4, but try one of the other codes listed for the brand of your particular VCR. If no other codes are listed, try each code, 000 through 72.

◀ When your remote control is in the “VCR” mode, the volume buttons still control your TV’s volume.

When your remote is in the “TV” mode, the VCR control buttons (PLAY, PAUSE, etc.) will still operate your VCR.

## SPECIAL FEATURES

### VCR Codes

Aiwa	00	Memorex	00, 09, 11	Sanyo	19, 20, 43
Akai	15, 22, 26, 30, 45, 66		13, 20, 21, 43	Scott	47, 53, 58, 60
Anam	71, 72	MGA	17, 30	Sears	09, 11, 16, 19
Broksonic	47, 53, 59	Minolta	16, 44		20, 27, 33, 43, 44
Capemhart	05	Mitsubishi	30, 37, 52, 61, 66	Sharp	21, 31
Canon/ Curtis Mathes	09	Mitsubishi (Unified)	17	Shintom	36
Craig	20, 65, 67	MTC	00, 65	Sony	02, 06, 07, 08, 09
Daewoo	03, 05, 18, 39, 68, 70	Multitech	00, 36	STS	16
Daytron	05	NAD	28	Sylvania	09, 17, 46
Dynatech	00, 21	NEC	12, 14, 15, 23, 34	Symphonic	00
Emerson	00, 01, 10, 11, 30, 35	Optonica	21, 31	Tandy	00, 43
	40, 47, 53, 56, 57, 59, 60	Panasonic	09, 63	Tatung	15
Fisher	20, 27, 33, 43	Penney	09, 12, 14, 16, 65	Teac	00, 15
Funai	00	Pentax	16, 32, 44	Technics	09
GE	09, 29, 32	Philco	09	Teknika	00, 09, 11, 25
LG	04, 11, 12	Philips	09, 31, 38, 46	TMK	10
Harman/Kardon	12, 37	Pilot	11	Totevision	11, 65
Hitachi	00, 15, 16, 32, 44, 51, 64	Pioneer Unified	28, 34	Toshiba	17, 18, 33, 58, 60
JCL	09	Portland	05	Unitech	65
Jensen	15	Pulsar	13	Vector Research	12, 14
JVC	15, 34, 55	Quartz	19, 49	Victor	34
Kenwood	15, 19, 34	Quasar	09, 41	Video Concepts	14, 30, 62
Lloyd	00	RCA	09, 16, 32, 44, 48, 54	Videosonic	65
Logik	36	RCA (Unified)	29	Wards	00, 09, 16, 20, 21
LXI	11	Realistic	00, 09, 11, 19, 20		31, 36, 48, 60, 65
Magnavox	09, 38, 42, 46, 48		21, 31, 33, 43, 65	Yamaha	12, 15
Marantz	09, 12, 38, 50	Ricoh	08	Zenith	07, 08
Marta	11	Samsung	18, 24, 26, 65	Zenith (Unified)	13
MEI	09	Sansui	15, 34, 67		

## SPECIAL FEATURES

### Setting Up Your Remote Control to Operate Your Cable Box

**1**  
Turn off your cable box.

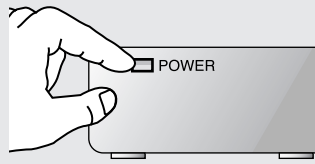

**2**  
On your Samsung remote control, press **SET**.

**3**  
Press the **CABLE** button on the top right of your remote control.

**4**  
Enter both digits of the cable box code listed below for your brand of cable box.

**5**  
Press **POWER**. Your cable box should turn on. If your cable box turns on, your remote control is now “set up” correctly.

**6**  
Once your remote control is set up, press the **CABLE** button any time you want to use the remote to operate your cable box.

◀ The remote control has three “modes”: “TV,” “VCR,” and “CABLE”.

Press the “CABLE” button to switch the remote control to the “Cable” mode.

◀ Make sure you enter both digits of the code, even if the first digit is a “0.” (If more than one code listed, try the first one.)

◀ If your cable box does not turn on, repeat steps 2, 3, and 4, but try one of the other codes listed for your particular brand of cable box. (If no other codes are listed, try each cable box code, 00 through 35.)

◀ When your remote control is in the “CABLE” mode, the volume buttons still control your TV’s volume. Also, the VCR control buttons (PLAY, PAUSE, etc.) will still operate your VCR.

#### Cable Box Codes

ABC	0, 07, 09, 12	Paragon	00	Starcom	02, 11, 19, 23
Antronix	26	Pioneer	16, 25, 31	Stargate	11, 18
Archer	26	Pulsar	00	Tandy	29
Comtronics	18	RCA	15	TeleCaption	27
Eagle Comtronics	18	Realistic	26	Texscan	22
Eastern	01	Regal	14, 30, 32, 34	Tocom	08, 09, 21
Gemini	11	Regency	01	Toshiba	00
General Instruments	07	Samsung	18, 25	Unika	26
Hamlin	06, 14, 30, 32	Scientific Atlanta	03, 05, 12, 33	United Artists	04
Hitachi	07	Signal	18	United Cable	02
Jerrold	02, 07, 10, 11, 19, 23	Signature	07	Universal	26
Memorex	00	SL Marx	18	Viewstar	29
Oak	04, 13, 28	Sprucer	15, 35	Zenith	00, 20
Panasonic	15, 24				



## SPECIAL FEATURES

### Fine Tuning Channels

Use fine tuning to manually adjust a particular channel for optional reception.

**1**

Select the appropriate channel.

Press **MENU** to display the menu.

Press **CH ▼** twice to select "Channel" menu.

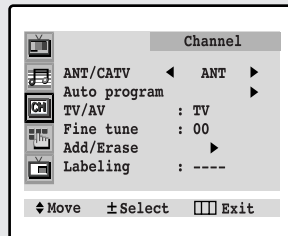

**2**

Press **VOL+** to select Channel menu.

Press **CH ▼** three times to select "Fine tune".

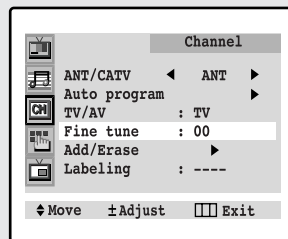

**3**

Press **VOL+** and **VOL-** to adjust the fine tuning.

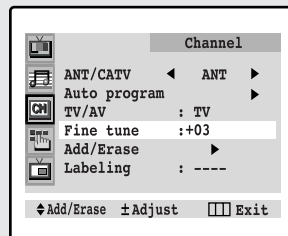

◀ After you adjust the fine tuning, the letters "\*" will appear when you press **DISPLAY** while watching this channel.

**4**

To store the fine tuning setting in the TV's memory, press **CH ▲**. (The letters "\*" will appear).

To reset the fine tuning to "00", press **CH ▼**.

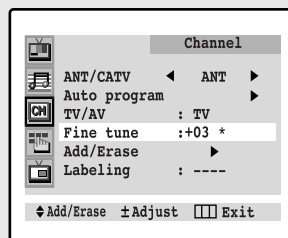

◀ Press the **MENU** button to resume normal viewing.

## Digital Noise Reduction

If the broadcast signal received by your TV is weak, you can activate the Digital Noise Reduction feature to help reduce any static and ghosting that may appear on the screen.

**1**

Press **MENU** to display the menu.

Press **VOL +** to select the "Picture" menu.

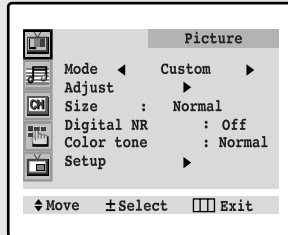

**2**

Press **CH ▼** three times to select "Digital NR."

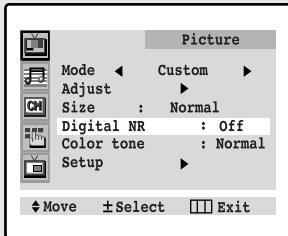

**3**

Press **VOL +** or **VOL -** to select Digital NR "On".

Press **MENU** twice to exit.

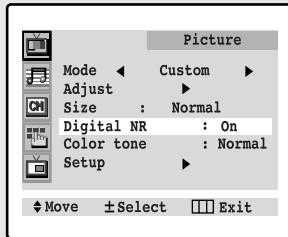

◀ Pressing **VOL-** or **VOL+** will alternate between "On" and "Off".

## LNA (Low Noise Amplifier)

(For models CL-29A5P/CL-29A6P/CL-29A7P/CL-29M6P/CL-34M9P)

If the TV is operating in a weak-signal area, sometimes the LNA function can improve the reception (a low-noise preamplifier boosts the incoming signal).

**1**  
Press the **MENU** button to display the menu.

Press the **VOL +** button to select the Picture menu.

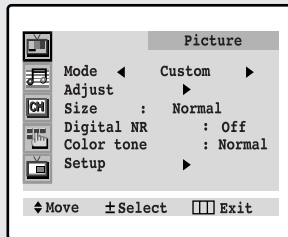

**2**  
Press the **CH ▼** button five times to select "Setup."

Press the **VOL +** button.

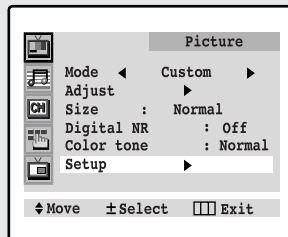

**3**  
Press the **VOL -** or **VOL +** button to select LNA "on."

Press the **Menu** button three times to exit.

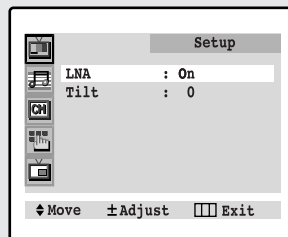

◀ Pressing **VOL -** or **VOL +** will alternate between "On" and "Off."

## SPECIAL FEATURES

### Tilt

Due to the Earth's magnetic field there may be some minor image tilt depending on the TV's location. When this occurs, follow the steps below.

#### 1

Press the **MENU** button to display the menu.

Press the **VOL +** button to select the Picture menu.

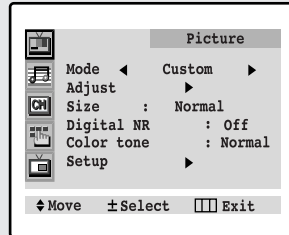

#### 2

Press the **CH ▼** button five times to select "Setup."

Press the **VOL +** button.

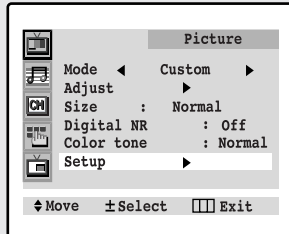

#### 3

Press the **CH ▼** button to select "Tilt."

Press the **VOL-** or **VOL+** buttons to adjust the Tilt.

Press the **Menu** button to exit.

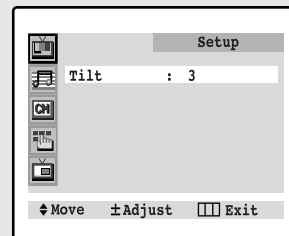

## Changing the Screen Size

### 1

Press **MENU** to display the menu.

Press **VOL +** to select the "Picture" menu.

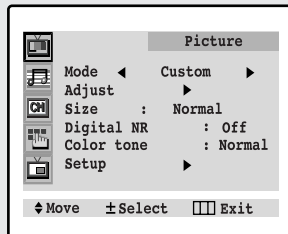

### 2

Press **CH ▼** twice to select "Size."

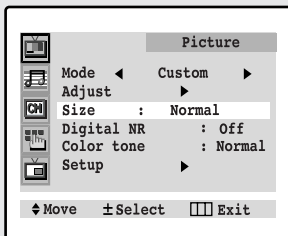

### 3

Press **VOL +** or **VOL -** repeatedly to select "Normal", "Zoom", or "Wide".

Press **MENU** twice to exit.

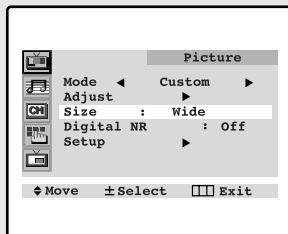

- **Normal** : Sets the picture to 4:3 normal mode. This is a standard TV screen size.
- **Zoom** : Magnifies the size of the picture on screen.
- **Wide** : Sets the picture to 16:9 wide mode.

## Using the R.Surf

This feature allows you to set the TV to return to a particular channel after a certain amount of time. For example, you may be watching a channel when commercials start. You can set the Surf to “5 minutes”, then switch channels. After minutes, the TV will return to the original channel. To use the R.Surf:

### 1

While you are watching the channel to which you want to return, press R.SURF . The on-screen display will read “Surf off” .

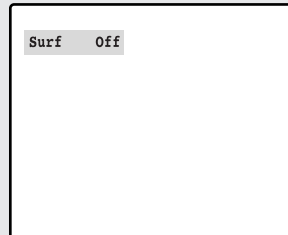

### 2

Press R.SURF again to set the timer in thirty second intervals, up to five minutes.



### 3

The time you set will begin counting down on the screen. When the time runs out, the TV will return to the channel you were watching when you set the timer.

## Setting the On/Off Timer

### 1

Press **MENU** to display the menu.

Press **CH ▼** three times to select "Function" menu.

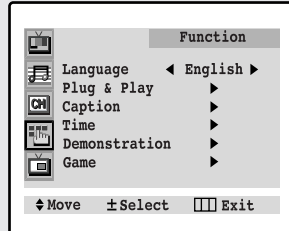

◀ Before using the timer, you must set the TV's clock. (See "Setting the Clock" on page 3.10).

When any of the timers are set, the "Timer" LED will illuminate (front panel of TV.)

### 2

Press **VOL+** to select the "Function" sub-menu.

Press **CH ▼** three times to select "Time".

Press **VOL+**.

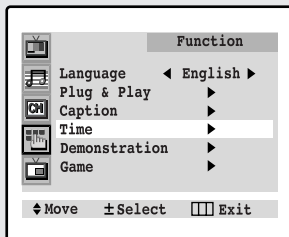

### 3

Press **CH ▼** to select "On time".

Press **VOL+** to select the "On time" hours. (The hours digits will be highlighted.)

Press **CH ▲** or **CH ▼** repeatedly to select the appropriate hours (i.e., the hour when the TV will turn on.)

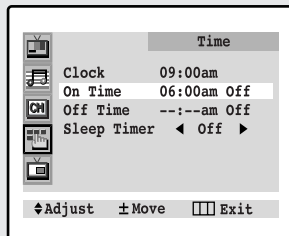

◀ When you set the hours, make sure the correct time of day (AM or PM) appears to the left of the hour.

### 4

Press **VOL+** to select the "On time" minutes. (The minutes digits will be highlighted.)

Press **CH ▲** or **CH ▼** to select the appropriate minutes.

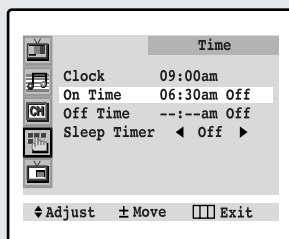

## SPECIAL FEATURES

### 5

Press **VOL +** to select "On/Off."

Press **CH ▲** (or **CH ▼**) to turn the on-timer "On." (Repeatedly pressing **CH ▲** or **CH ▼** will alternate between on and off.)

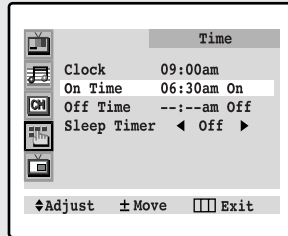

### 6

When finished, press **VOL +**.

### 7

To set the Off time, press **CH ▼** to select "Off time."

Press **VOL +** and set the hours and minutes. (Follow the same procedure as in steps 1-6 above.)

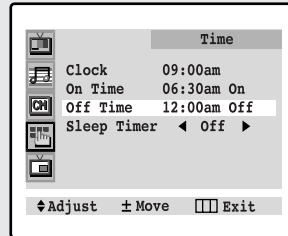

### 8

When finished setting the timer, press **MENU** three times to exit.

◀ To deactivate the "On time," select "Off" during this step.

◀ If no function buttons (including remote control buttons or front panel buttons) are operated for three hours after the TV is turned on by "On time", the TV will be automatically turned off.

## Setting the Sleep Timer

The sleep timer automatically shuts off the TV after a preset time (from 10 to 180 minutes).

### 1

Press the **SLEEP** button on the remote control.

### 2

Press **SLEEP** repeatedly until the appropriate time interval appears (any of the preset values from "Off" to "180").

◀ After about 5 seconds, the sleep display will disappear from the screen, and the time interval will be set.



## Sound Features

### Choosing a Multi-Channel Sound (MTS) Soundtrack

Depending on the particular program being broadcast, you can listen to stereo, mono, or a Separate Audio Program. (SAP audio is usually a foreign-language translation. Sometimes SAP has unrelated information like news or weather.)

**1**  
Press **MTS** repeatedly to select "Mono", "SAP", or "Stereo".

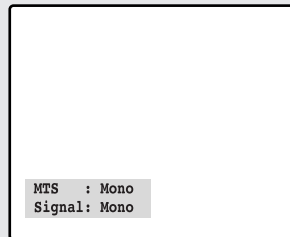

◀ The text at the bottom of the menu tells you if the incoming audio is stereo, SAP, or mono.

- Choose *Stereo* for channels that are broadcasting in stereo.
- Choose *Mono* for channels that are broadcasting in mono, or if you are having difficulty receiving a stereo signal.
- Choose *SAP* to listen to the Separate Audio Program, which is usually a foreign-language translation.

## SPECIAL FEATURES

### Extra sound settings (Turbo Sound, Surround, Auto Volume or Virtual surround)

- **Turbo Sound**

Turbo sound emphasizes the bass and treble frequencies to add fullness to the sound.

- **Surround**

Your TV can create a “Surround” effect such that the sound seems to come from all directions. Once the “Surround” is set to “On” or “Off”, the setting applies to the sound effects such as Standard, Music, Movie and Speech.

- **Auto Volume**

Each broadcasting station has its own signal conditions, which can make it necessary to adjust the volume every time the channel is changed. “Auto volume” lets you automatically adjust the volume of the desired channel by lowering the sound output when the modulation signal is high or by raising the sound output when the modulation signal is low.

- **Virtual surround**

This function allows the TV L/R speakers to provide a home-like Dolby effect. The center and surround sounds are mixed up into the L/R speakers.

#### 1

Press **MENU** to display the menu.

Press **CH**▼ once to select the “Sound” menu.

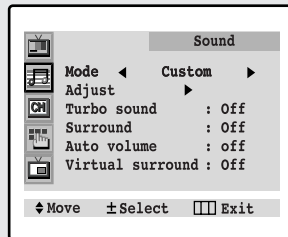

#### 2

Press **VOL +** to select the Sound menu.

Press **CH**▼ twice to select “Turbo sound”.

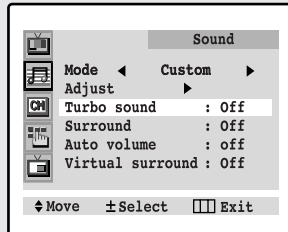

#### 3

Press **VOL +** to select “On”.

Press **MENU** twice to exit

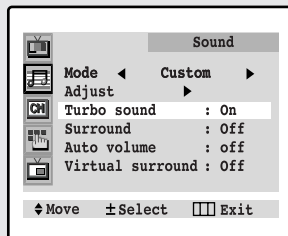

◀ You can set Surround, Auto volume, and Virtual surround as the same way of setting Turbo sound.

## Viewing Closed Captions

Your TV decodes and displays the closed captions that are broadcast with certain TV shows. These captions are usually subtitles for the hearing impaired or foreign-language translations. All VCRs record the closed caption signal from television programs, so home-recorded video tapes also provide closed captions. Most pre-recorded commercial video tapes provide closed captions as well. Check for the closed caption symbol in your television schedule and on the tape's packaging: .

**1**  
Press **MENU** to display the menu.  
  
Press **CH ▼** three times to select the "Function" menu.  
  
Press **VOL+**.

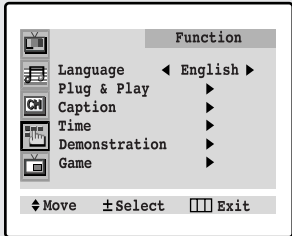

**2**  
Press **CH ▼** twice times to select the "Caption" menu.  
  
Press **VOL+** to open the Caption menu.

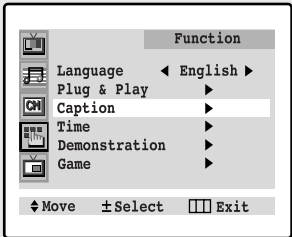

**3**  
Press **VOL+** or **VOL -** to turn closed captioning on/off.

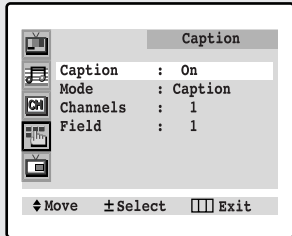

**4**  
Press **CH ▼** to highlight "Mode."  
  
Press **VOL -** or **VOL +** to select "Caption" or "Text."

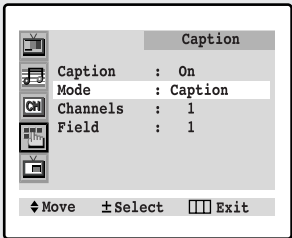

**5**  
Depending on the particular broadcast, it might be necessary to make changes to "Channels" and "Field":  
Use the **CH ▲**, **CH ▼**, **VOL +** and **VOL -** buttons to make the changes. (Follow the same procedure as in steps 3-4 above.)  
Press **MENU** three times to exit.

◀ Misspellings and unusual characters sometimes occur during closed caption transmissions, especially those of live events. There may be a small delay before captions appear when you change channels. These are not malfunctions of the TV.

◀ In **caption mode**, captions appear at the bottom of the screen, and they usually cover only a small portion of the picture.

In **text mode**, information unrelated to the program, such as news or weather, is displayed. Text often covers a large portion of the screen.

◀ Different channels and fields display different information: Field 2 carries additional information that supplements the information in Field 1. (For example, Channel 1 may have subtitles in English, while Channel 2 has subtitles in Spanish.)

## Viewing Picture-in-Picture

(For models CL-29A5P/CL-29A6P/CL-29A7P/CL-29M6P/CL-34M9P)

You can use the PIP feature to simultaneously watch two video sources.  
 Note: The PIP feature does not work with DVD signals.

When PIP is selected in the Zoom mode, the Mode is automatically converted into the Normal mode.

### Activating Picture-in-Picture

**1**

Press the **Menu** button to display the menu.

Press the **CH**▼ four times to select the PIP menu.

Press the **VOL +** to select the PIP menu.

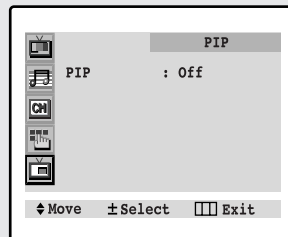

◀ Quick way to access the PIP menu: Simply press the PIP/SIZE button on the remote control:

**2**

Press the **VOL +** to select PIP "On."

Press the **Menu** button twice to exit.

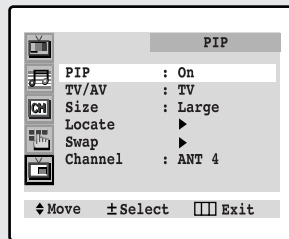

◀ If you turn TV off while watching and turn it on again, the PIP window will disappear.

### Selecting a Signal Source (External A/V) for PIP

Press the **TV/VIDEO** button repeatedly to cycle through all of the available signal sources: "TV," "AV1," "AV2," and "S-Video."

◀ For more information about external A/V components and signals, see "Viewing a VCR or Camcorder Tape" on page 3.16.

If you select "TV", the PIP image is the same as the main image.

### Changing the Size of the PIP Window

Press the **PIP/SIZE** button repeatedly to cycle through this sequence: PIP ON with large window, PIP ON with small window, and PIP OFF.

## SPECIAL FEATURES

### Changing the Location (Rotating) the PIP Window

**1**

Press the **Menu** button to display the menu.

Press the **CH▼** four times to select the PIP menu.

Press the **VOL +** button to select the PIP menu.

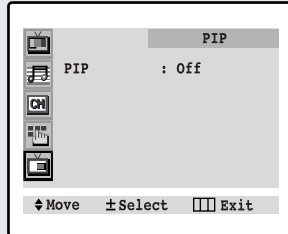

**2**

Press the **VOL +** button to select PIP "On."

Press the **CH▼** three times to select the Locate.

When you press **VOL +** repeatedly, the PIP window moves from corner to corner on the TV screen.

Press the **Menu** button twice to exit.

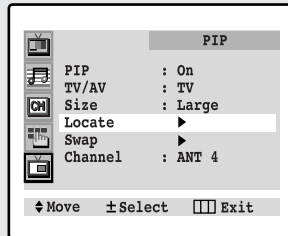

### Swapping the Contents of the PIP image and Main image

When you press the **SWAP** button:  
The image in the PIP window will appear on the main screen, and vice versa.

### Changing the PIP Channel

Press the **PIP CH▲** or **CH▼** button to change the channel that appears in the PIP window.

## SPECIAL FEATURES

### Enjoying Games

You can enjoy the game (Chicken Farm), programmed in this TV.

#### 1

Press **MENU** to display the menu.

Press **CH ▼** three times to select the "Function" menu.

Press **VOL +**.

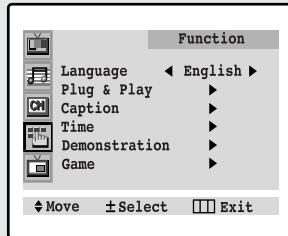

#### 2

Press **CH ▼** five times to select the "Game" menu. Press **VOL +**.

The **READY** window will be displayed.

Press **VOL +** or **VOL -** to run the game.

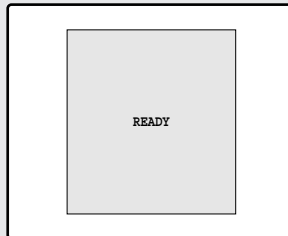

#### 3

Move the farmer to catch eggs by using **VOL +** or **VOL -**. Every time the scores go up, the speed of game becomes faster bit by bit.

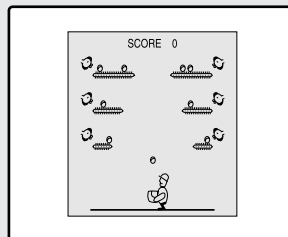

#### 4

Every time you catch fifty eggs (i.e., 50, 100, 150 ...), if any broken egg exists, one egg can be restored. When five eggs are lost, the game will be over and simultaneously the final score window will be displayed.

To exit the Game mode, press the **TV/VIDEO** button.

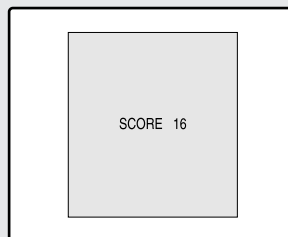

◀ If you want to stop during the game, press **MENU**. Then, the final score window will be displayed.

If you want to re-start the game, press the **MENU**, **VOL-** or **VOL+**. Then, the final score window will be switched to the **READY** window.

## SPECIAL FEATURES

### Viewing the Demonstration

To become familiar with the various menus provided by your television, you can view the inbuilt demonstration.

#### 1

Press **MENU** to display the menu.

Press **CH** ▼ three times to select the "Function" menu.

Press **VOL** + .

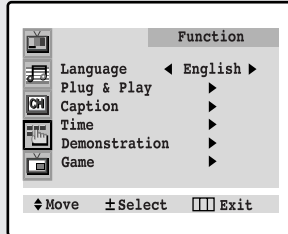

#### 2

Press **CH** ▼ four times to select "Demonstration" menu.

Press **VOL** + .

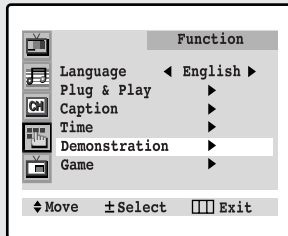

#### 3

Each of the menu options is displayed in turn.

When you wish to stop the demonstration, press any button on the remote control.

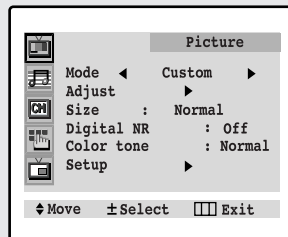

# Chapter Five

## TROUBLESHOOTING

If the TV seems to have a problem, first try this list of possible problems and solutions. If none of these troubleshooting tips apply, then call your nearest service center.

### Identifying Problems

<b>Problem</b>	<b>Possible Solution</b>
Poor picture	Try another channel. Adjust the antenna. Check all wire connections.
Poor sound quality.	Try another channel. Adjust the antenna.
No picture or sound.	Try another channel. Press the TV/VIDEO button. Make sure the TV is plugged in. Check the antenna connections.
No color, wrong colors or tints.	Make sure the program is broadcast in color. Adjust the picture settings. If the set is moved or turned in a different direction, the power should be OFF for at least 30 minutes.
Picture rolls vertically.	Adjust the antenna. Check all wire connections.
The TV operates eratically	Unplug the TV for 30 seconds, then try operating it again.
The TV won't turn on.	Make sure the wall outlet is working.



## Cleaning and Maintaining Your TV

With proper care, your TV unit will give you many years of service. Please follow these guidelines to get the maximum performance from your TV.

### Placement

- Do not place the TV near extremely hot, cold, humid or dusty places.
- Do not place the TV near appliances with electric motors that create magnetic fields, such as vacuum cleaners.
- Keep the ventilation openings clear; do not place the TV on a soft surface, such as cloth or paper.
- Place the TV in a vertical position only.

### Liquids

- Do not handle liquids near or on the TV. Liquids that spill into it can cause serious damage.

### Cabinet

- Never open the cabinet or touch the parts inside.
- Wipe your TV with a clean, dry cloth. Never use water, cleaning fluids, wax, or chemicals.
- Do not put heavy objects on top of the cabinet.

### Temperature

- If your TV is suddenly moved from a cold to a warm place, unplug the power cord, and allow at least two hours for moisture that may have formed inside the unit to dry completely.

## Using Your TV in Another Country

If you plan to take your TV with you to a foreign country, please be aware of the different television systems that are in use around the world. A TV designed for one system may not work properly with another system due to differences in the TV channel frequencies

## Specifications

Model	CL-29A5P / CL-29A5W / CL-29A6P / CL-29A6W / CL-29A7P / CL-29A7W / CL-29M6W / CL-29M6P / CL-34M9P
Voltage	AC 100-240V
Frequency of Operation	60Hz
Power Consumption	160 Watts